

PRESERVING “BAIXA POMBALINA” THROUGH LOW INTRUSIVE SEISMIC REHABILITATION METHODS. THE COMREHAB PROJECT

V. CÓIAS E SILVA
Stap, SA, Lisbon, Portugal

SUMMARY

The problem of seismic behaviour of the old buildings in Lisbon. Case of the “Pombaline” historical downtown. Main deficiencies. Intervention strategies. Techniques based on FRP composite materials. Presentation of a system for seismic rehabilitation under development within the framework of the “COMREHAB” Eureka project.

1. INTRODUCTION

About 50% of Lisbon’s built stock is made up of old buildings with stone masonry walls, which present obvious structural insufficiencies. Amongst the old buildings in Lisbon, the "Baixa Pombalina" - downtown area - is unique. Built after the big earthquake of 1775 was, in several aspects, innovative [1]. In the structural plan, anti-seismic features, unknown until then, were introduced systematically and intentionally.

The main problems presented today by the buildings that make up the "Baixa Pombalina" are (Fig. 1):

- a) Building of extra floors
- b) Alterations, notably on the ground floor, which have been incorrectly carried out with the weakening of walls and foundations
- c) Careless introduction of steel and reinforced concrete elements.
- d) Deterioration of the properties of structural wood elements



Figure. 1: “Baixa Pombalina” buildings, showing main deficiencies

2. INTERVENTION STRATEGY

New materials, like advanced composites, made of epoxy or polyester resin matrix, aggregating high resistance synthetic fibres, can be applied in innovative solutions to improve the seismic behaviour of old masonry buildings. The fact that these materials have strengths 5 to 10 times higher than steel and are 4 times lighter give rise, in the construction sector, to a set of new possibilities of "dry" structural interventions (meaning, without the use of hydraulic materials), low-invasive and reversible. They can also be used in conjunction with other solutions, such as with energy dissipation devices.

In view of a detailed study of the possibilities offered by composite materials, an "Eureka-Eurocare" application by the name "COMREHAB" was submitted in 1997. This application was approved becoming project EU1939. The research program of the Portuguese partner will involve an expenditure of almost 100,000,000 PTE (half a million Euros).

3. “COMREHAB” GOALS

In general terms, the purpose of the project is to develop low cost composite materials and simple installation techniques for application in the strengthening of existing structures. In its Portuguese component, the COMREHAB project is aimed at developing a strengthening system capable of ensuring the buildings a seismic behaviour equivalent to a “Basic Safety Objective, BSO (ATC, 1996):

- ?? Protection of the residents lives in case of a relatively frequent (short return period) medium earthquake
- ?? Prevention of collapse for the relatively rare (long return period) maximum earthquake.

4. SYSTEM DESCRIPTION

4.1 General

The compression strength of walls in old buildings, either made of two layers of good quality stone enclosing a lower quality filling, or consisting of successive layers of stone laid with lime mortar, can be improved through adequate confinement [2]. If, furthermore, the walls are given a tension resisting "reinforcement", it is possible to increase their bending resistance, both in plane and out of plane. This is the goal of the system being developed in the frame of COMREHAB project. The system is made up of i) confinement connectors, ii) strengthening laminate and iii) accessories. The two main elements are so designed that they will work together, although they can also be applied each one on its own, if only a moderate improvement in the compression strength of the wall is required.

4.2 Confinement connectors

Their function is to increase wall strength through bracing or hooping, capable of preventing its bulging through the relative displacement of its two faces (fig. 2).

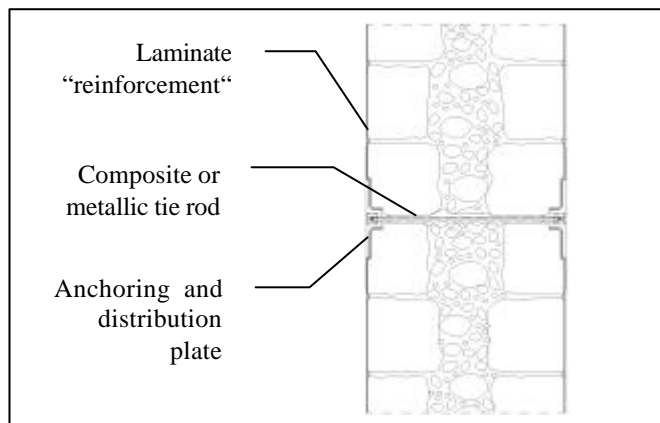

Figure 2: Confinement connector

The distribution plates can be provided with calibrated springs, so that a constant pre-determined tension can be ensured. These plates can be done without when the face of the wall is lined with laminate reinforcement, the tie rod being directly anchored in the laminate.

4.3 Reinforcement laminates

Designed as a composite material of high strength fibres, pre-impregnated with epoxy resin makes the reinforcement laminate can be assembled "in situ" or prefabricated. Its function is to resist the tension and compression forces, its contribution being prompted by the confinement connectors. It is applied in two layers that will work together, thus making a resistant membrane or laminate, in just one or in both wall faces. The first layer, designated as bond ply, is made of flexible uni-directional stripes of fibres pre-impregnated with non-polymerised resin with appropriate out life. The width of the stripes varies between one and a few decimetres.

These stripes, placed usually diagonally in the wall face, follow its irregularities, particularly the joints between successive stone or brick layers, which are previously enhanced and cleaned.

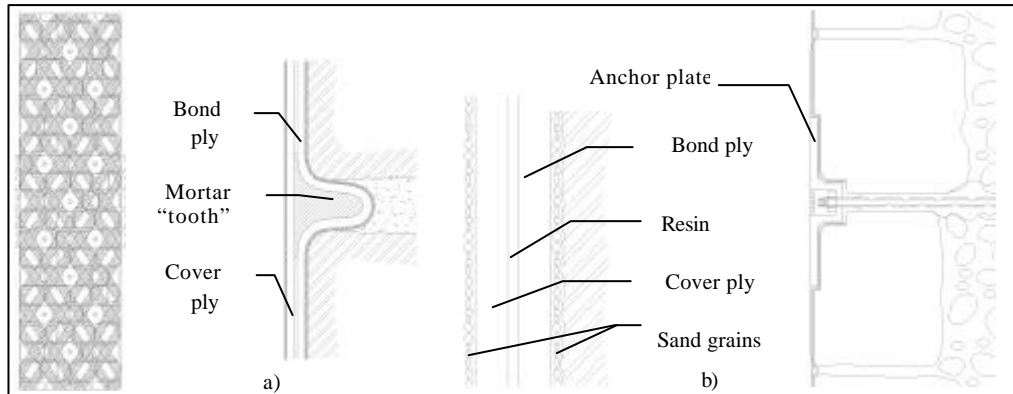

Figure: 3 - Reinforcement laminate a) In the inside face of a wall, general and adherent "tooth" detail; b) Reinforcement laminate and anchor plate

The appropriate moulding of these stripes to the joints and irregularities of the wall can be achieved either manually or applying a pneumatic "cushion" under pressure. The stripes will cross each other over, under, to the left and to the right of the recesses to lodge the anchor plates and the confinement connectors (fig. 3 a), left). The stripes that will form the bond ply will have the inside face so treated as to enhance the mechanical contact with the wall surface, whereas the opposite face will be finished in such a way as to enable easy gluing of the other layer (fig. 3 b), left). After installing the stripes that form the bond ply, its polymerisation and cure is promoted by heating.

Finally, the stripes that make up the cover ply are installed. These stripes are placed over the previous ones, in such a way that their side treated to improve the mechanical bond will be facing out, while the side treated for easy gluing will be facing inside. This second layer is, therefore, identical to the first one, but placed the other way around.

Between the first and second layers, distribution elements, made in the same composite material, can be placed, following the recesses where the anchor plates are installed, in which they will be pressed when tensioning the tie rods.

After the polymerisation, the different layers make a high strength and stiffness laminate, well adjusted to the wall surface, on one or both sides, pressed against it by the connectors. When the reinforced wall is subjected to out of plane flexion, the laminate will tend to slide in relation to the wall face. Due to the presence of the connectors, it is however, prevented from doing so by the surface irregularities, the mechanical bond and friction enhanced by the sanded finish and the shear resistance of connectors and tie rods. Under these conditions, the laminate, due to its higher stiffness, will be under tension and compression forces, alleviating the masonry. The laminate will resist to the tension forces without problems. Under compression forces the laminate will tend to separate, in which it will be prevented by the tension resistance of the connectors and tie rods. The trend towards the laminate sliding relatively to the wall when this is subjected to in plane flexion, is opposed by the three mechanisms described previously. When the wall is only subjected to an additional compression, the laminate resistance is immediately called upon, due to its higher stiffness. The trend towards bulging is counteracted as described above. The wall's high inertia will prevent any trend towards the buckling of the laminate, whose slenderness, if isolated, would be too high.

4.4 Advantages and innovative aspects of the system

In relation to the traditional strengthening methods, this system presents the following advantages:

- ?? Lower disturbance of the users, particularly important in residential buildings
- ?? Lower intrusiveness in what concerns the original structure, of particular importance in architectural heritage buildings. After rendering the system is completely invisible. The increase in thickness is irrelevant, in the order of a few millimetres only and can be hidden in the render thickness
- ?? Reversibility, of particular interest for architectural heritage. The connector plates can be disassembled, the tie rods can be removed, and afterwards the laminate can be cut and striped.

The system exploits a symbiosis of an old material element, with low resistance but a high inertia, and an advanced material element, of a high resistance and stiffness but small inertia. The examples of this type of application of composite materials so far consist of simply gluing the composite laminate, generally stiff flat bars, to the masonry [3], applying reinforced grids [4] or wet lay-ups, bonded to the masonry. The connection laminate/masonry, simply of mechanical nature, is based on the confining effect of the connectors, and has, therefore, a reversible character. The innovative aspects of the design have been patented.

5. RESEARCH AND TESTING PLAN

In the first phase, studies concerning the technical and economical feasibility were done, as well as simple laboratory testing program to assess, in a first approach, the increase in the simple bending and bending/compression resistance, achieved through the strengthening system.

In a second phase large-scale laboratory testing on complete wall elements will be carried out, in a shaking table.

- A) In the wall plane, cyclical load testing will be performed, on specimens with approximate dimensions of $L = 1,50$, $W = 0,40$ and $H = 3,20$ (m) (fig. 4a)
- B) In the perpendicular plane, sinusoidal excitation tests will be performed on specimens with $L = 0,20$, $W = 1,20$ and $H = 2,00$ (m) (fig. 4b)

At the end of the second phase, large scale tests in shaking table on models representing an outside wall (fig. 5a) and a complete building (fig. 5b) are envisaged.

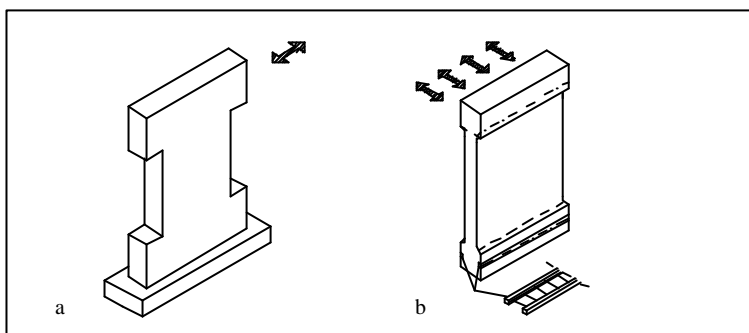

Figure 4: - Shaking table tests on wall specimens: a) in plane, b) out of plane

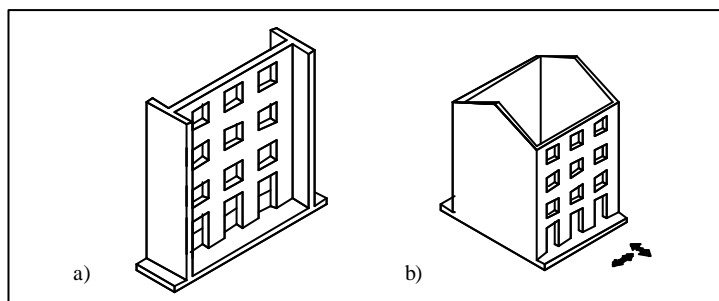

Figure 5: - Shaking table tests on models: a) Entire facade wall, b) Entire building

During this phase complementary modelling studies will be carried out, based on linear and non-linear analysis methods, static and dynamic, aiming at an additional adjustment to the design and sizing criteria.

Finally, in the third phase, the validation of the new technology will be sought, through its application in the seismic rehabilitation of a real building in Lisbon.

The building to be selected will be subjected to a set of tests, based on dynamic identification, before and after the intervention, so the effects of the strengthening will be evaluated. The experimental results will be compared with the modelling results.

The information gathered in the meantime will allow for the production of a set of documents aiming at the exploitation and dissemination of the system, namely **Guidelines**, to facilitate the practical implementation of the system by structural designers and specifiers and **Manuals** to enable training of specialised workers, in view of the actual jobsite work.

6. FINAL REMARKS

Although globally the problem of seismic rehabilitation of existing masonry buildings is vast and complex, such rehabilitation can be achieved, in many cases, through simple and low intrusive interventions. The COMREHAB project aims at developing techniques based on the use of composite materials that will allow interventions with the mentioned characteristics.

Low intrusive solutions have, as well, the advantage of allowing for the preservation of the character and authenticity of city areas, such as “Baixa Pombalina”, which make up an heritage that can not be appropriated, let alone, degraded and devalued by the present generation.

7. REFERENCES

- [1] Córias e Silva, V. *m Novo Modelo (e uma Nova Visão) do Edificado Pombalino de Lisboa* - “Monumentos”, (DGEMN), Nº. 6, Lisboa, Mar. 1997
- [2] Binda, L. e Modena, C. *Examples of interventions in ancient constructions*, Structural analysis of historical constructions II, CIMNE, Barcelona, 1998
- [3] analysis of historical constructions II, CIMNE, Barcelona, 1998
- [4] Klein, P e Winkler N. *Application of Carbon Fibre Products CFP in Constructions*, Newtech, Lisboa, Julho de 1997.
- [5] Sofronie, R; *“Antiseismic reinforcement of Mansonary Works”*; Newtech, Lisboa, Julho de 1997.